

SAND DOLLAR FILTER SYSTEMS REPLACEMENT PARTS LIST MANUFACTURED 2009 AND BEYOND

REPLACEMENT PARTS

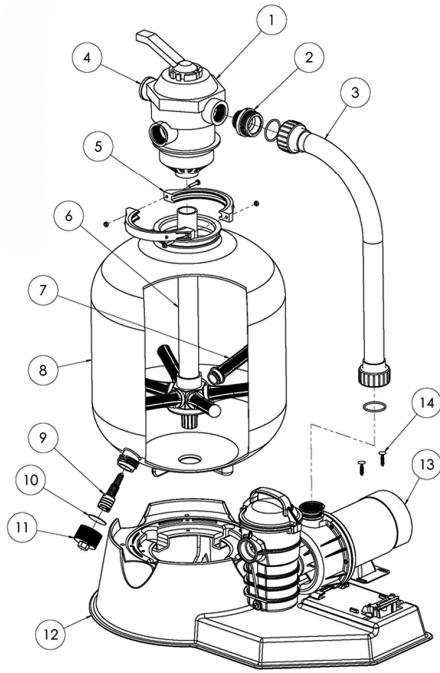

SAND DOLLAR FILTER SYSTEMS		
Item No.	Part No.	Description
1	262506	Valve 1-1/2 Inch, 6-Way
2	354588	Adaptor, NPT to Buttress
3	155709	Pump to Filter Assy (Dynamo to SD35)
3	155710	Pump to Filter Assembly (Dynamo to SD40)
3	155711	Pump to Filter Assembly (Dynamo to SD60)
4	190059	Pressure gauge
5	152165	Clamp Assembly
6	152229	Pipe assembly - SD35
6	152228	Pipe assembly - SD40
6	152227	Pipe assembly - SD60
7	150084	Lateral SD35 & SD40
7	150085	Lateral SD60
8	145339	Tank with drain SD35

8	145341	Tank with drain SD40
8	145343	Tank with drain SD60
9	154711	Sand Drain
10	154715	Gasket (Sand Drain)
11	154712	Drain cap
12	155333P	Systems Base
12	155333CP	Systems Base, CSA Pump
13	Dynamo	Pump
14	710009	Base Hardware Kit

NOT SHOWN

Item No.	Part No.	Description
	155151	Kit, Flex Hose, 6ft. ¹
	155005	Kit, Flex Hose, 12ft. ¹

1: Replacement Hose Kits include two (2) hoses, four (4) hose adaptors, and four (4) hose clamps